



KUT-KWIK UNDERCUTTER MODEL KK50 INSTRUCTIONS & PARTS LIST

AIR MOTOR:

Connect to an air supply with line pressure of approximately 90 p.s.i. A Martindale Automatic Filter-Lubricator must be used to keep the motor adequately lubricated. Failure to do so will void warranty. The angle head should be greased through the flush fitting on the right side of the head after every 8 hours of operation. Attach grease tube to gun, insert nozzle in fitting and pump 4 to 5 times while squeezing the tube. Grease the gear case, which is located between the air motor body and the spindle housing, in same manner after every 250 hours of operation..

SAWS & V-CUTTERS:

This Kut-Kwik Undercutter uses Tungsten-Carbide saws and V-cutters with 3/4" & 7/8" diameter x 5/16" hole. Saws cut a "U" shaped slot and are stocked in .001" thicknesses increments from .010" to .065". "V"-cutters cut a "V" shaped slot which stays clean longer; they are .030" to .065" thick and are stocked with 40°, 50°, or 60° between cutting edges.

OPERATION:

To attach the saw arbor rotate spindle by hand until holes line up in shaft and housing. Insert lock pin through hole. Screw the arbor into the head. Put saw or V-cutter on saw arbor making sure saw is seated on shoulder. DO NOT OVER TIGHTEN.

When putting the saw on undercutter head, saw teeth should point counter-clockwise. When tightening the saw holding nut, DO NOT USE THE PIN WRENCH TO HOLD THE SPINDLE. Use two 3/8" wrenches on the arbor & nut flats. Rotate nylon depth gauge to allow desired depth of cut. With saw to operator's left, start cut at riser and pull toward operator. Experience will show operator the proper cutting rate. When the saw or V-cutter gets dull, change it to keep a rapid cutting speed without overloading.

KUT-KWIK UNDERCUTTER MODEL KK50 PARTS LIST

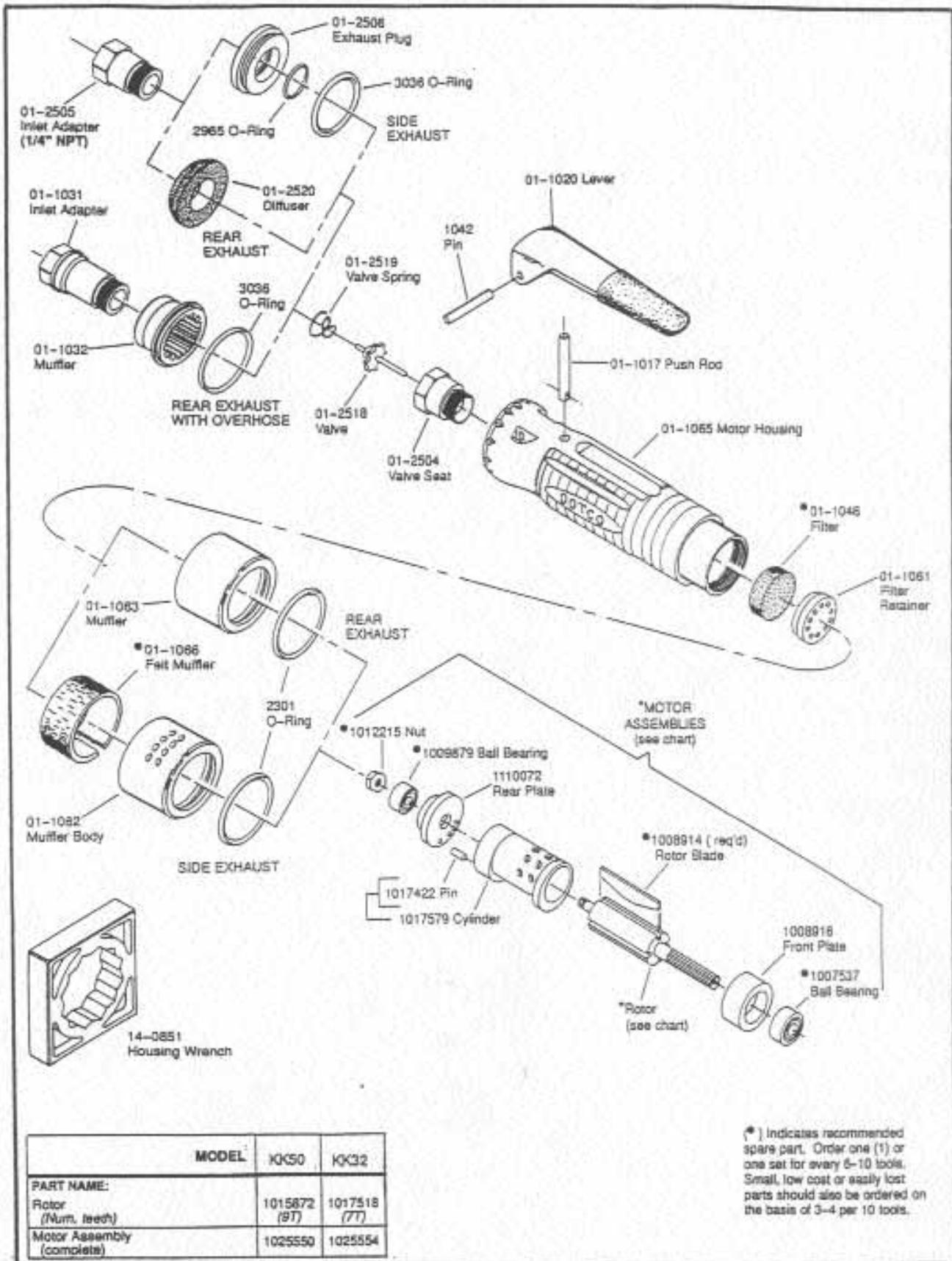

	MODEL	KK50	KK32
PART NAME:			
Rotor (Num. Teeth)		1015872 (97)	1017518 (77)
Motor Assembly (complete)		1025550	1025554

KUT-KWIK UNDERCUTTER MODEL KK50 PARTS LIST

(*) Indicates recommended spare part. Order one (1) or one set for every 5-10 tools. Small, low cost or easily lost parts should also be ordered on the basis of 3-4 for every 10 tools.

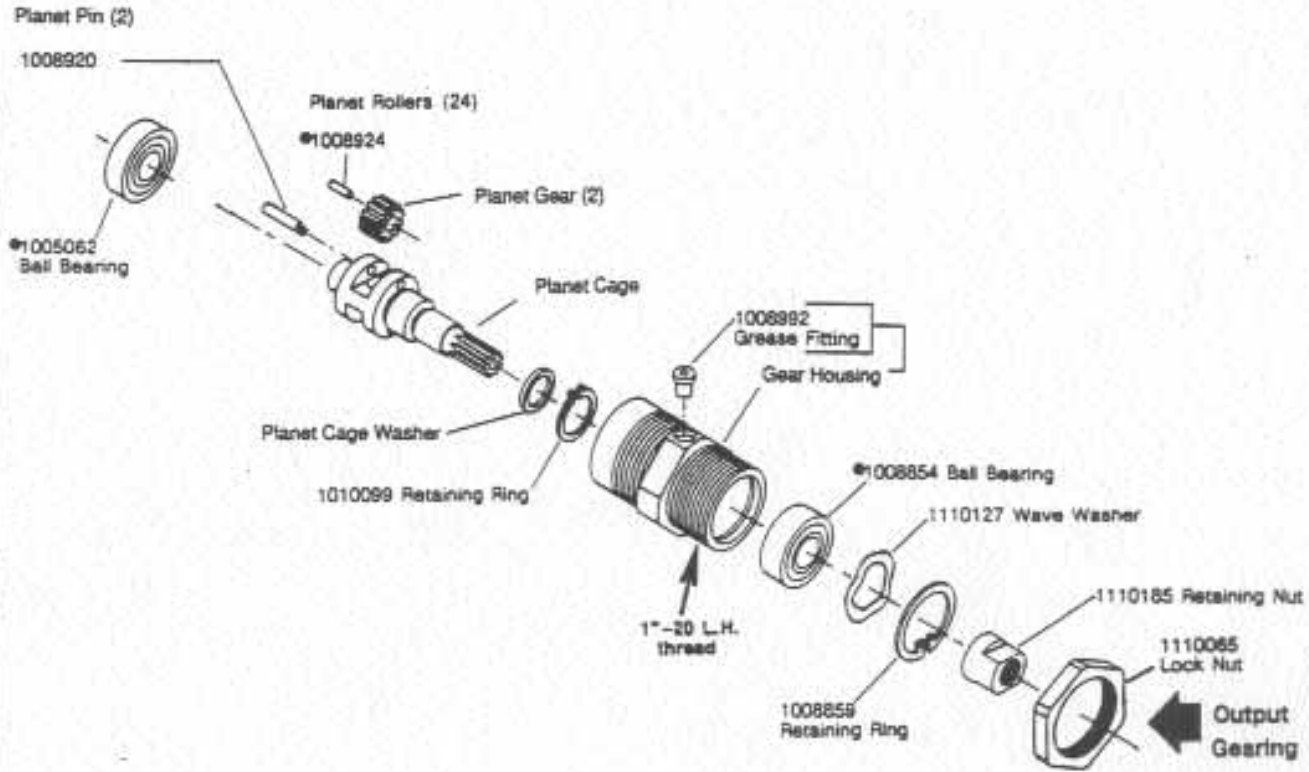

MODEL:	KK50	KK32
Part Name		
	<i>OUTPUT</i>	
Planet Cage Washer (inside diameter)	1110054 (0.486")	1110055 (0.534")
Gear Housing (num. teeth)	1110046 (39T)	1110047 (43T)
Planet Cage	1110223	1110225
Planet Gears (2 each)	1008973 (14T)	1008968 (17T)
Bearing Adapter	—	—

KUT-KWIK UNDERCUTTER MODEL KK50 PARTS LIST

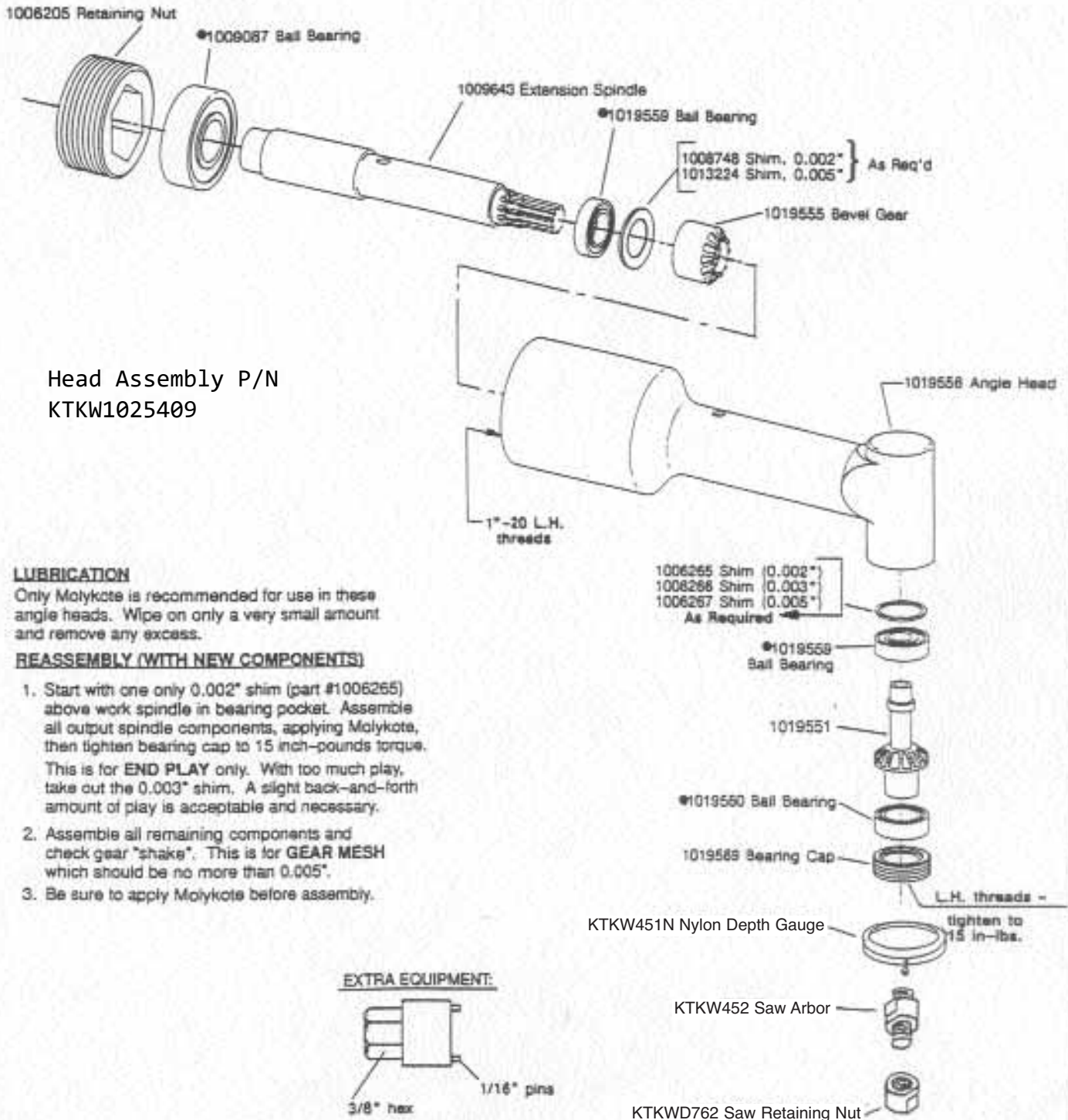

Head Assembly P/N
KTKW1025409

LUBRICATION

Only Molykote is recommended for use in these angle heads. Wipe on only a very small amount and remove any excess.

REASSEMBLY (WITH NEW COMPONENTS)

1. Start with one only 0.002" shim (part #1006255) above work spindle in bearing pocket. Assemble all output spindle components, applying Molykote, then tighten bearing cap to 15 inch-pounds torque. This is for **END PLAY** only. With too much play, take out the 0.003" shim. A slight back-and-forth amount of play is acceptable and necessary.
2. Assemble all remaining components and check gear "shake". This is for **GEAR MESH** which should be no more than 0.005".
3. Be sure to apply Molykote before assembly.

EXTRA EQUIPMENT:

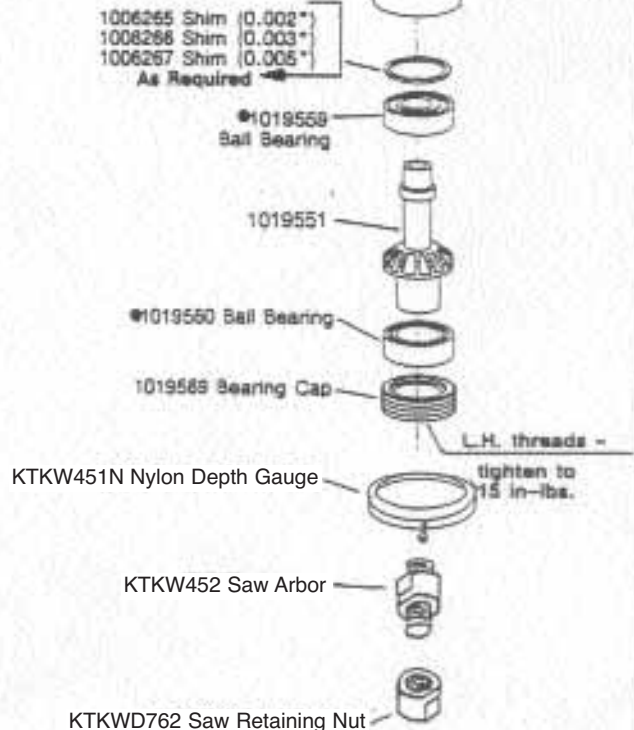
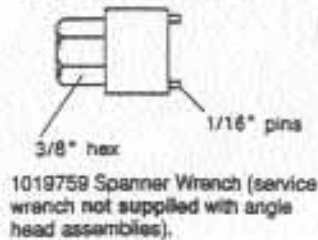

(*) Indicates recommended spare part. Order one (1) or one set for every 5-10 tools. Small, low cost or easily lost parts should also be ordered on the basis of 3-4 per 10 tools.